

# SYMBIOTE® Quick Reference

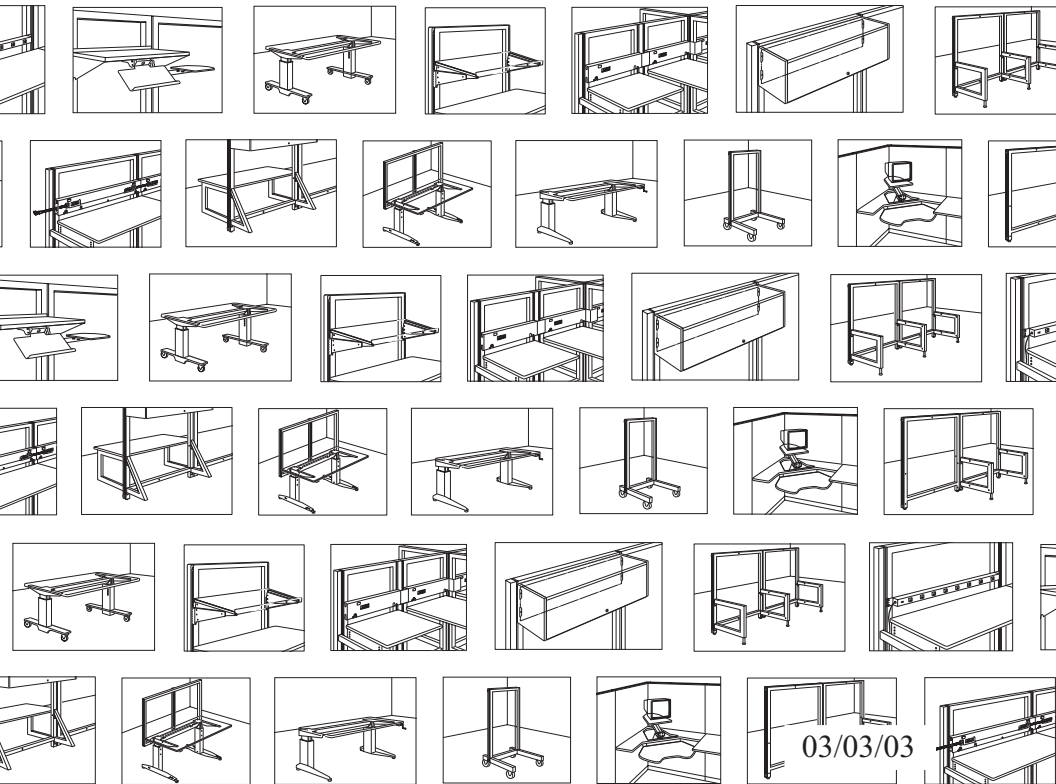

03/03/03

---

# Table of Contents

FRAMES AND CONNECTORS .....	3
ERGOSTATS™ AND TABLES .....	5
WORK SURFACES AND SUPPORTS .....	6
SHELVING .....	7
STORAGE AND DISPLAY .....	8
ELECTRICAL AND AIR .....	9
CABLE MANAGEMENT .....	11
RACK MOUNT .....	12
COMPUTER SUPPORT .....	13
MATERIAL HANDLING AND ASSEMBLY .....	14

## FRAMES AND CONNECTORS

- **ULTRA FRAMES** provide 1" incremental adjustment of components.
- Frame widths are 24", 30", 36", 48" and 60".
- Frame heights are 48", 62", 80" and 96".
- Use **TOTALOCK CASTERS** when specifying mobile stations.
- When connecting two mobile stations, you must specify **JOINER PLATES**.
- Frame weight loads are 1,000 pounds per side per frame evenly distributed on glides, 500 pounds per side on casters.
- **PANEL CONNECTORS** are used for frame-to-frame connections.
- **FRAME SPINES** divide 48" or 60" wide frames vertically for additional hanging capacity.

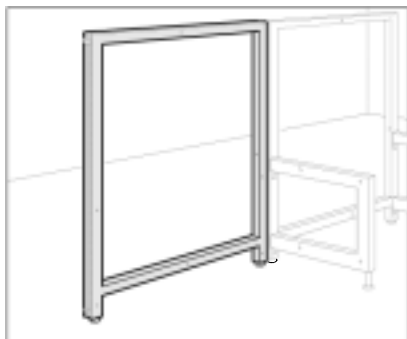

Ultra Frame

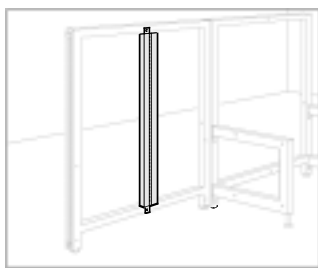

Frame Spine

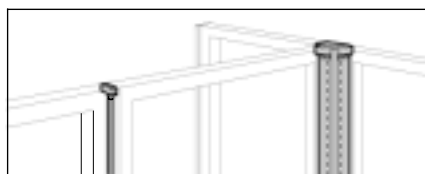

Panel Connector

- Use **MID C LEGS** for support. They support two adjacent work surfaces using only one support.
- **A LEGS** are used when only minimal support is required on back side of frame run (15" deep components or less).
- In line **CONNECTOR POSTS** add 3 inches to a run of frames. **C** or **A LEGS** can be attached to **CONNECTOR POSTS**, enabling components to mount vertically in any position on the frame.
- Support all runs over 8' long with a **C LEG** or a return frame.
- **FABRIC** or **LAMINATE PANELS** are also available.  
**NOTE: C LEGS** do not attach to panels.
- **ESD** paint is optional (use only when required).



C Leg



A Leg

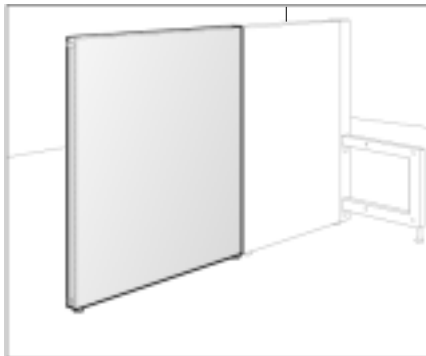

Laminate Panel

---

## ERGOSTATS™ AND TABLES

- Height adjustable ERGOSTATS™ available electric or positionable.
- ERGOSTATS™ are available with casters or glides.
- Unlike tables, ERGOSTATS™ accommodate RISER FRAMES for 1" incremental adjustment of components.
- To accommodate the riser, ERGOSTAT™ legs extend 8" from the back of the frames.
- RISER FRAMES have 250 pound load capacity.
- Height adjustable WORKTABLES available electric or positionable.
- Height adjustable TABLE BASES available electric or positionable.
- WORKTABLES are double sided, allowing two workers to share the same space.
- WORKTABLES require WORKTOPS. TABLE BASES require ULTRA SURFACES.
- Load capacity is 500 pounds, evenly distributed.

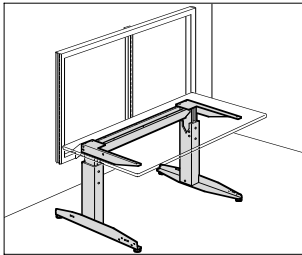

ErgoStat™

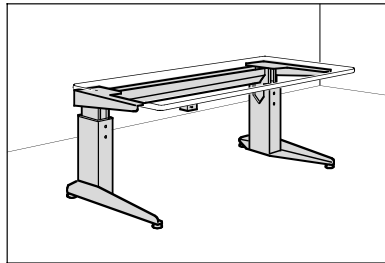
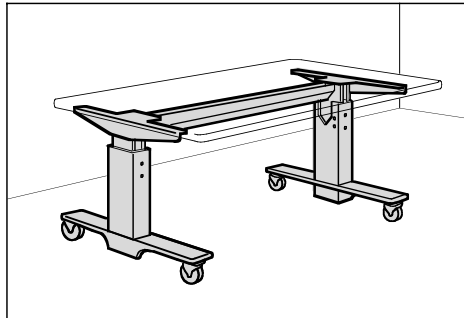

Table Base



WorkTable

## WORK SURFACES AND SUPPORTS

- Standard work surface depths are 24", 30" and 36".
- Standard work surface widths are 24", 30", 36", 48", 60", 72" and 96".
- **ULTRA SURFACES** are used on everything except **WORKTABLES**.
- Available with **EDGE-BAND** or **FULL ROUND** comfort edges.
- Load capacity is 500 pounds, evenly distributed.
- Available with standard or ESD laminate or in solid Maple.
- **CORNER WORK SURFACES** and **PENINSULA SURFACES** available.
- **POWERTOP®** height adjustable corner work surfaces available.
- Custom work surfaces (size, color, finish, detail) available.
- Supports not included, order separately – **B SUPPORTS** or **CANTILEVERS**.
- **STRETCHER BARS** and **REINFORCEMENT BARS** used in conjunction with return panels can increase weight capacity of work surfaces to 1,000 pounds.
- Support all work surfaces over 60" with a center **CANTILEVER**.
- ESD grounding hardware included with ESD laminate work surfaces, must specify **WRIST STRAP GROUNDING KIT** with each work surface for worker attachment.

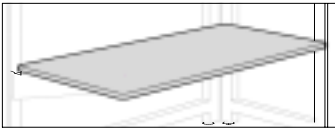

Ultra Surface



Stretcher & Reinforcement  
Bars

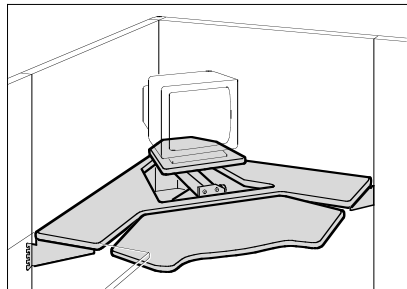

PowerTop®

---

## SHELVING

- **MULTI-FUNCTION** and **GENERAL PURPOSE SHELVES** are 24", 30", 36", 48", 60" and 72" wide. ESD paint optional.
- **MULTI-FUNCTION SHELVES** and **GENERAL PURPOSE SHELVES** mount flat or sloped. Available 15", 18" and 24" deep. 200 pound load capacity.
- **LOW PROFILE SHELVES** allow for greater density of storage.
- **MULTI-FUNCTION SHELVES** and **LOW PROFILE SHELVES** available vented for air circulation.
- **GENERAL PURPOSE SHELVES** mount flat, 8 or 16 degrees.
- **GENERAL PURPOSE SHELVES** allows cord drop at back of shelves when mounted on closed panels.
- **CENTER SHELVES** mount inside frames, provides access to storage on both sides of frames, flat or sloping. Load capacity is 200 pounds.
- **CORNER SHELVES** available with standard or ESD laminate. Available 15" and 18" deep, 24", 30", 36" and 48" wide. 200 pound load capacity.
- **WIRE SHELVES** available.
- **ROLL-OUT SHELVES** mount on frames. 200 pound load capacity. Available 24" deep, and 24", 30" and 36" wide.
- **STORAGE SHELVES** available with low or high sides and mount sloped or flat. Available 15" deep, 24", 30", 36", 48", and 60" wide. Load capacity 200 pounds.

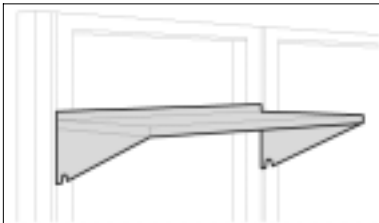

Multi-function Shelf

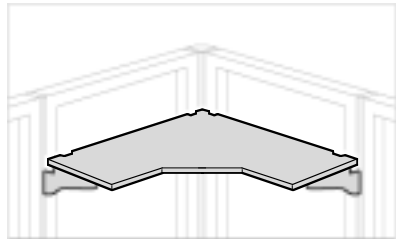

Corner Shelf

## STORAGE AND DISPLAY

- **STORAGE CABINET ASSEMBLIES** (flipper door units) available.
- **TASK DRAWERS**, mobile or suspended from work surface available. Various configurations and keying options.
- Single and double sided **TACKBOARDS** and **MARKER BOARDS** available for frame mounting.
- **PEGBOARDS** mount inside **ULTRA FRAMES**.

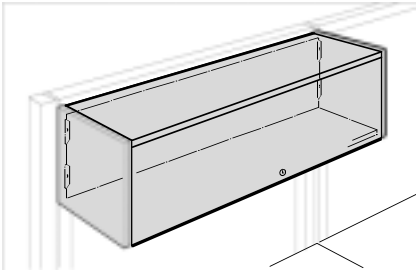

Storage Cabinet

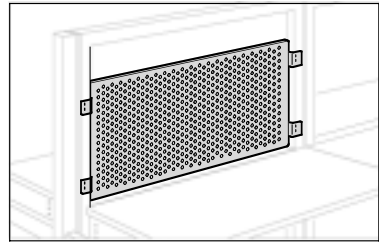

Pegboard

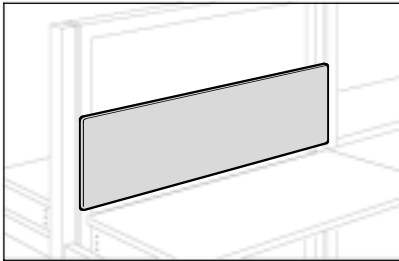

Tackboard

## ELECTRICAL AND AIR

- **TASK LIGHTS** available with magnetic or electronic ballasts.
- Lights mount under shelves or on **CANTILEVER LIGHT BRACKETS**.
- Standard (2 bulbs) or Parabolic (2 or 4 bulbs) lenses available.
- Specify **SHELF MOUNT LIGHT BRACKETS** and **CANTILEVER LIGHT BRACKETS** separately.
- **GENERAL TASK LIGHTS** available, mount under shelves only.
- **15 and 20 AMP PLUG STRIPS** available, can be mounted horizontally or vertically on frames.
- Circuit breakers are standard on **PLUG STRIPS**.
- **20 AMP PLUG STRIPS** provide surge protection.
- **WIREMOLD® POWER CHASES** can be mounted horizontally on hanger clips or vertically on **POWER/DATA BRACKETS**.
- Wiring devices and finished faceplates to be supplied by electrical contractors.
- **POWER/DATA BRACKETS** specified separately.
- **UTILITY DISTRIBUTORS** provide frame mounted electrical, air and voice/data distribution throughout workstations with access on both sides of the distributor when using **ULTRA FRAMES**.
- 8-wire systems distribute up to three 20 AMP circuits using 15 AMP receptacles.

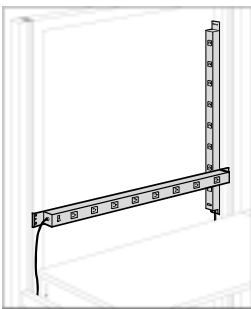

15 amp Plug Strip

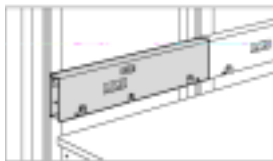

Utility Distributor

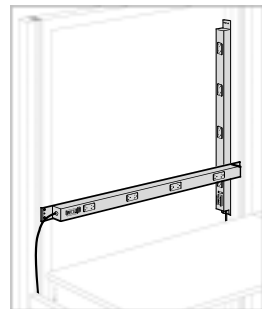

20 amp Plug Strip

- **QUICK DISCONNECT FITTINGS** available factory installed.
- **UTILITY DISTRIBUTORS** meeting specifications on inside corners require factory modification, consult catalog specifications.
- **POWER ENTRY, POWER JUMPERS** and **SIMPLEX RECEPTACLES** specified separately.
- **FILLERS** available to enclose the ends and cover **POWER JUMPERS**.

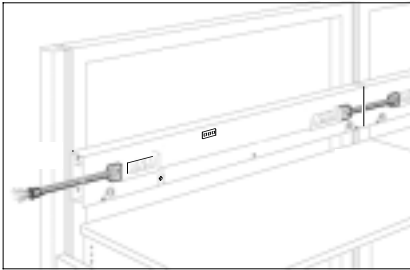

Power Entry and  
Power Jumper Cables

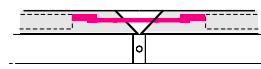

frame to frame

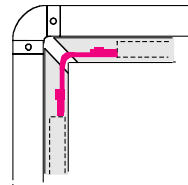

90° corner

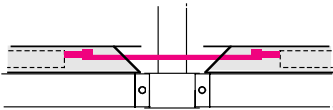

Connector Post

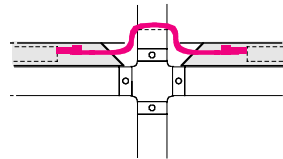

four-way

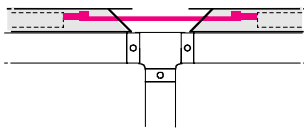

three-way

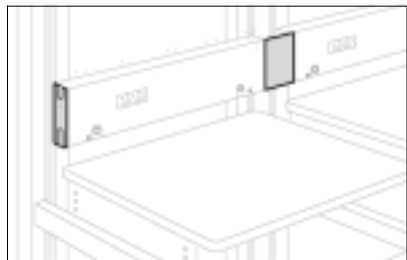

Three-way & End Fillers

---

## CABLE MANAGEMENT

- **CABLE DUCTS** and **RING DUCTS** mount vertically or horizontally to route cables.
- Overhead cable management provided by **FULL** or **HALF CABLEWAYS** or **CABLE RUNWAY LADDERS**.
- **WIREMOLD® DATA CHASES** and **12 PORT DATA CHASES** provide horizontal or vertical cabling chases to be populated by data contractor.
- **POWER/DATA BRACKETS** for vertical mounting of **WIREMOLD® DATA CHASES** specified separately.

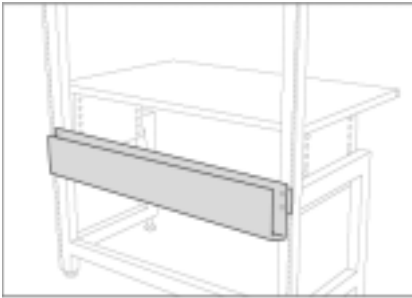

Cable Tray

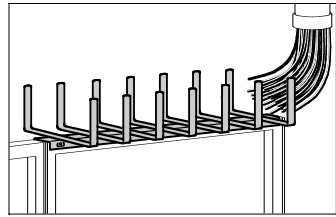

Cableway

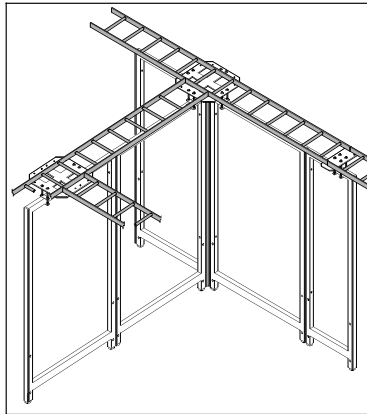

Cable Runway Ladder

## RACK MOUNT

- **RACK MOUNT ASSEMBLIES** mount to 24" wide frames.
- Supports 19" EIA standard electrical devices.
- **RACK MOUNT** is available in three heights accommodating 12, 20 and 40 EIA units. Available depths are 5", 15" and 24".
- **RACK MOUNT BRACKETS** available in 2 and 4 EIA units in flush, 5" and 11" depths. Available for 24" and 30" wide frames.
- To enclose the rack, **SIDE** and **FRONT PANELS** are available.
- **STATIONARY** and **ROLL-OUT SHELVES** available.
- **RACK MOUNT CABLE DUCT** available for routing cables.

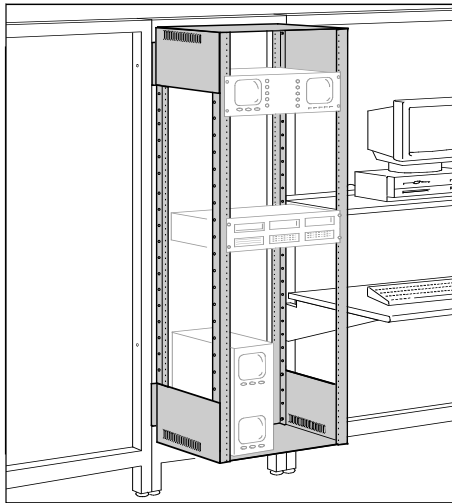

Rack Mount Assembly

## COMPUTER SUPPORT

- **KEYBOARD** and **MOUSE TRAYS** available for shelf or surface mounting.
- Articulating **MONITOR ARMS** mount on surfaces or frames, **KEYBOARD TRAYS** also available.
- **PIVOT ARMS** can be end mounted on frames, center mounted between frames, saddle mounted to inside of frames, or with surface clamps to attach directly to work surfaces.
- **PIVOT ARMS** available with single or double arms to provide additional adjustment.
- **PIVOT ARMS** support **DOCUMENT HOLDERS**, **MONITOR TRAYS** with or without **KEYBOARD TRAYS** and **PIVOT BIN RAILS**.

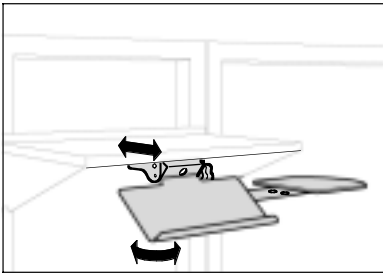

Keyboard Tray, Shelf Mount  
with Mouse Tray

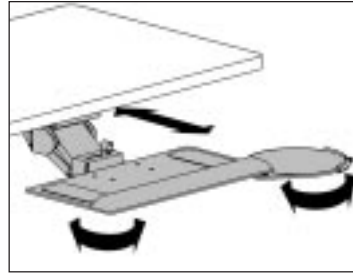

Keyboard Tray, Surface Mount  
with Mouse Tray

## MATERIAL HANDLING AND ASSEMBLY

- Overhead **TOOL TRAVELERS** available.
- **BIN RAILS, DISPENSING RAILS** and **TOTE RAILS** mount to frames and adjust vertically in one inch increments.
- **SUBCONTAINERS** mount on **DISPENSING RAILS** or inside of **TOTES**.
- **TOTES** can hang on **TOTE RAILS** or be used as drawers with **TOTE FRAMES**.
- **MOBILE CARTS** available single sided, 52" and 66" high and 24" or 30" wide. **HANDLES** and **END COVERS** available separately. Carts permit 1" incremental adjustment of components.
- **MOBILE CART** load capacity is 500 pounds, evenly distributed.
- Optional laminate **MOBILE CART BASES**, 24" deep available.

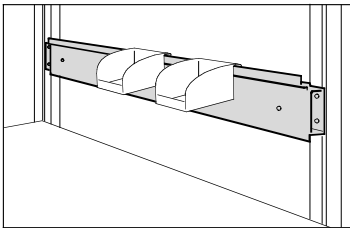

Bin Rail

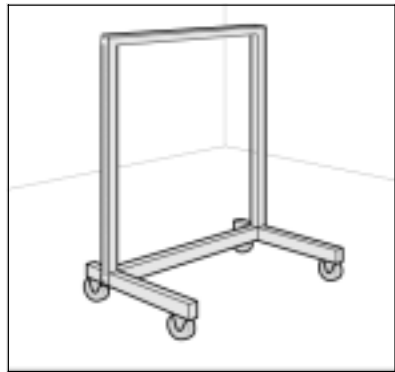

Mobile Cart

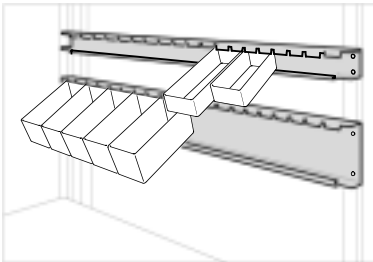

Dispensing Rail and  
Subcontainers

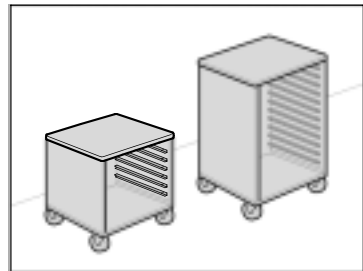

Mobile Tote Frame

---

## NOTES

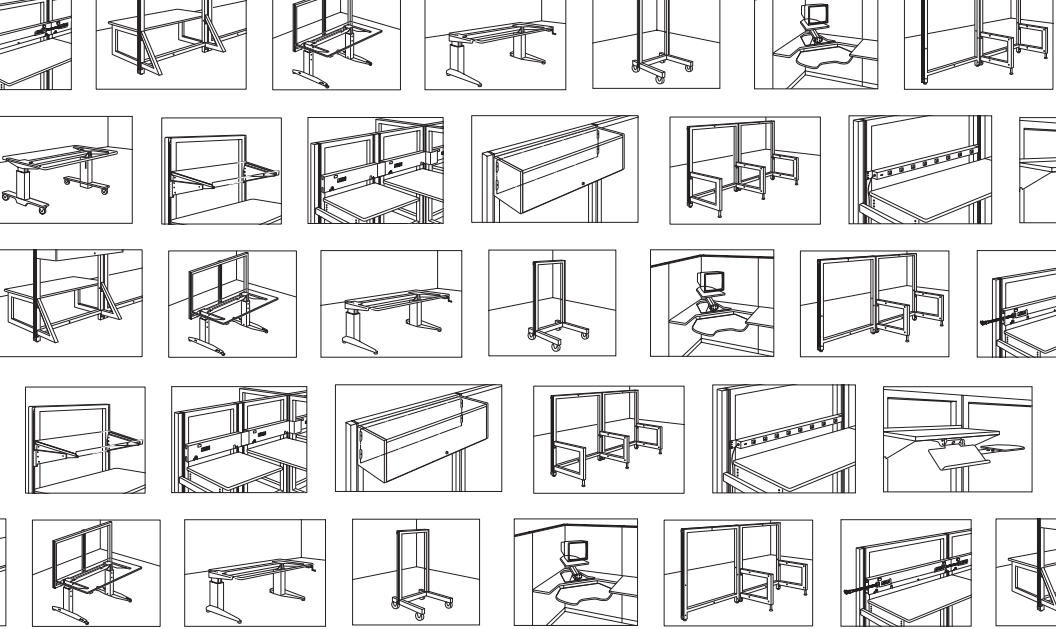

300 North Centennial Street Zeeland, MI 49464  
Phone: (616) 772-1790 Fax: (616) 772-1798  
[www.symbiote.com](http://www.symbiote.com)

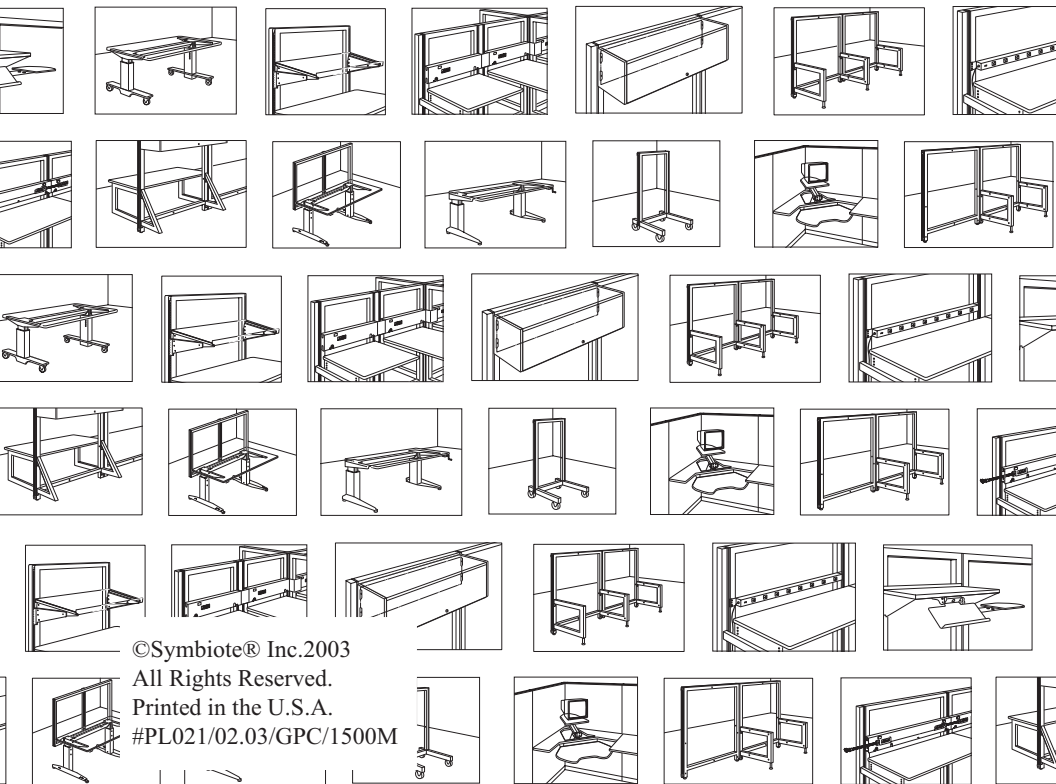

©Symbiote® Inc.2003  
All Rights Reserved.  
Printed in the U.S.A.  
#PL021/02.03/GPC/1500M